

For more information on XCMG products, dealer services,
and industry solutions, visit us on the web at www.xcmg.com

Jan 1, 2014
All Rights Reserved

Materials and specifications are subject to change without notice.
Featured machines in photos may include additional equipment.
See your XCMG dealer for available options.

apply to all similar docs: XCMG, WWW.XCMG.COM, their respective logos, "XCMG For Your Success",
as well as the corporate and product identity used herein,
are trademarks of XCMG and may not be used without permission.



XCMG For Your Success



XUZHOU CONSTRUCTION MACHINERY GROUP IMP. & EXP. CO., LTD



XCMG Headquarters, Xuzhou Economic Development Zone,
Jiangsu, China 221004



(+86-516) 87739230



XCMG Regional Departments:

West Asia & North Africa	(+86-516) 87739251 87739202 87739223
Asia-Pacific	(+86-516) 87739500 87739529 87739233
Central Asia	(+86-516) 87739218 87739239 87739510
North America	(+86-516) 87739285 87739551 87739713
South America	(+86-516) 87739196 87739714 87739187
Africa	(+86-516) 87739501 87739222 87739709
Europe	(+86-516) 87739238 87739271 87739228



export@xcmg.com



WWW.XCMG.COM

Engine model	YC6B125-T21
Rated power(kW)	92
Operation mass(kg)	10000
Rated bucket capacity(m³)	1.8
Total cycling time(s)	11

LW300FN

WHEEL LOADER

High-efficiency Excellent reliability Heritage of Classics Maturity & Stability

Model Characteristics

- High Efficiency, energy-saving and powerful.
- Three-element torque converter and dead-axle power shift gearbox, featuring maturity and excellent reliability.
- 2,600mm wheelbase, delicate and flexible, applicable to various sites.
- Bucket made of high-strength material, resistant to wear and impact.
- Multiple configurations and complete work tools, adaptable to construction requirements of diversified areas and working conditions.
- Optional air conditioner and sound insulation & noise reduction for elaborate and comfortable operation environment.

Performance advantages

- Prominent capacity, with traction force $\geq 9.0t$ and breakout force $\geq 12.0t$.
- Delicate and flexible with turn radius of 5,160mm (tire center).

Market status

- Best-seller in the industry of 3t single model



EXCELLENT power and drive system

Powerful

- China II emission standard, high performance and low fuel consumption.
- Powerful and high torque reserve coefficient, able to meet loads requirement instantly and provide power required for operations with heavy and large load.



Classic & Reliable

Gearbox and Torque Converter Assembly

- Dead-axle power shift gearbox, featuring maturity and excellent reliability.
- Three-element torque converter guarantees maximum utilization of engine power.
- Flange of drive shaft complies with international standard with increased diameter of fixing bolt circle, featuring extra-strong resistance to torque for continuous operation with high strength and heavy loads.



Excellent Reinforced Drive Axle

- All load-bearing parts are thick and solid with good capacity against overload, satisfying requirements for various operations with high strength and large loads.

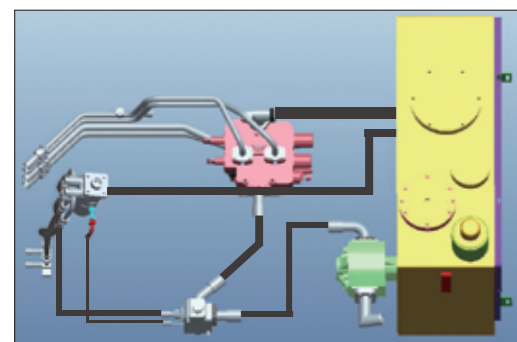

Hydraulic and Electric Element of International Quality

- First-class hydraulic element, featuring low pressure loss, less system heat and high part reliability.
- Italian α hydraulic hose featuring resistance to heat and pressure, and long service life.
- Two layers of sealing, i.e. 24° cone plus O-rings up to DIN international standard are employed for hydraulic pipelines, which features better tightness and effectively resolves the issue of leakage.
- Imported materials are used for harness with optimized process layout for guaranteeing circuit system reliability.

SOLID AND STURDY frame structure and bucket

Extra-strong Structure

- Finite element analysis is fully applied to structural parts to decrease stress concentration and eliminate local weaknesses, demonstrating complete application to various working conditions.



Bucket Optimization

- Sharp lengthen bucket bottom, easier to cut in with more materials collected.
- Diminished opening angle and reduced section for easy pushing-in and hoisting.

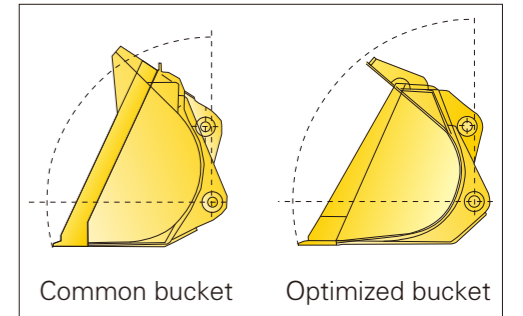

Diversification Of Selections

- Standard bucket is universally applicable to various working conditions,
- Rock bucket is dedicated to solid materials, such as rock, resistant to wear and impact,
- Coal bucket is dedicated to loose materials, such as coal, featuring large volume and high efficiency.

CAPACIOUS AND COMFORTABLE driving space



Luxurious cab up to automobile level featuring large space and broad view, without dead visual area, bringing about a safe and comfortable driving experience.



Operation elements and buttons at the fingertips can easily realize various operations; fully-covered exquisite interiors and rubber floor provide best operation environment.



Full-view rear window, high mounted rear lamp and equipment for reverse alarm provide good vision and safe

EASY AND CONVENIENT maintenance

- Owing to frame structure of engine hood, upturning side door and large opening angle, maintenance of engine and radiator becomes much easier.
- With concentrated fuse box, operation status of electrical system is uniformly displayed, featuring easy maintenance.
- Measuring points for system pressure are concentrated, saving both time and labor for maintenance.
- Oil return circuit of hydraulic oil tank is designed with independent cavity, which guarantees maintenance convenience.



Various operation devices are suitable for requirements of diversified operations

Clamp: used for pick-up and transfer of various woods and pipe fittings.

Grass-catch machines and tools: used for farm, biological power station, paper mill, etc. Pick-up and transfer of various light materials.

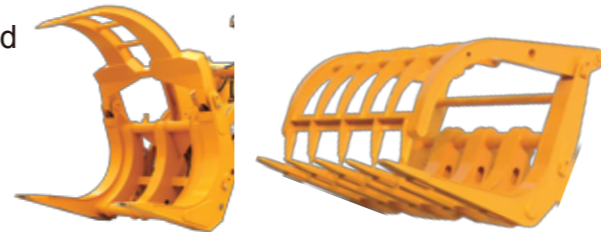

Parameters of Transforming work tools

Item	Toad's Mouth Clamp	Grasping grass machine	Pallet fork	Unit
Rated load	3	3	3	t
Dumping height(main blade plate)(frontal dumping)	2784	3025	3012	mm
Dumping distance(main blade plate)(frontal dumping)	1134	2028	1614	mm
Horizontal lifting height	-	-	3500	mm
Maximum dumping angel	45	20	25	°
Maximum opening size	1576	2800	-	mm
Minimum clamping diameter	Ø580	Ø1045	-	mm
Fork retracting angle	-	-	23	°
Length of tool	-	-	1700	mm
Width of tool	1650	2198	2012	mm
Height of tool	-	-	890	mm
Length of fort tooth	-	-	1050	mm
Overall demension: (L x W x H)	7120×2300×3025	7540×2300×3025	7379×2300×3290	mm

Overall Demension

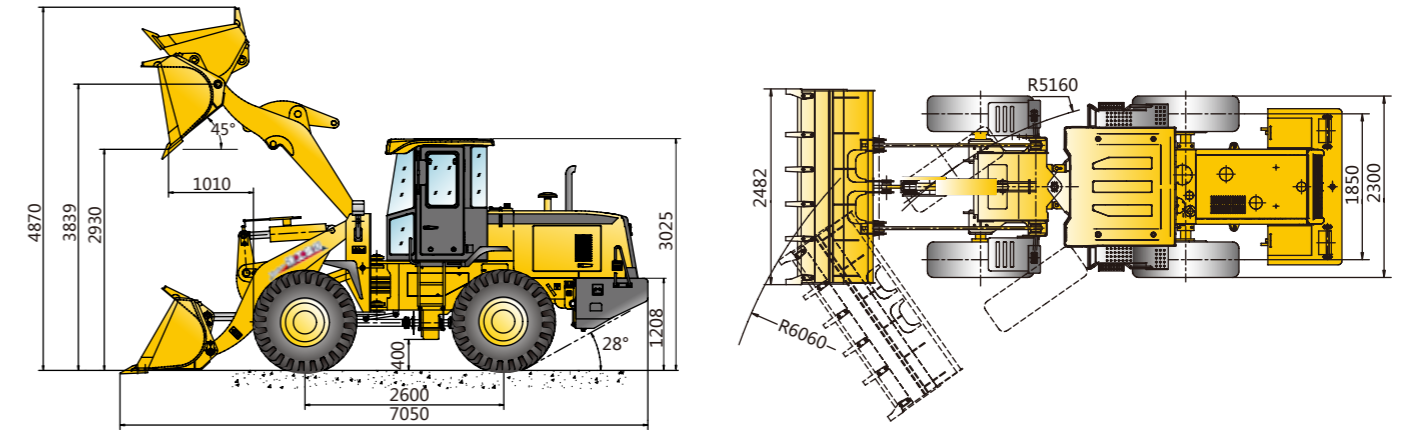

Item	Standard movable arm			High Lift Unloading Arm			Unit
	Standard bucket	Rocket bucket	Enlarge bucket	Standard bucket	Enlarge bucket	Enlarge bucket	
Bucket capacity: Stack loading	1.8m³	1.5m³	2.1m³	1.5m³	1.8m³	2.1m³	m³
Bucket capacity: Flat loading	1.8	1.5	2.1	1.5	1.8	2.1	m³
Width of bucket	2482	2482	2482	2482	2482	2482	mm
Dumping height	2930	2948	2854	3268	3244	3174	mm
Dumping distance	1010	987	1081	1120	1144	1245	mm
Working height (height-rising)	4870	4820	4970	5090	5140	5360	mm
Total length	7050	6936	6970	7168	7202	7202	mm
Turning radius (outside of bucket)	6060	6050	6010	6280	6310	6310	mm
Digging depth : 0°	55	55	55	96	96	96	mm
10°	230	205	228	245	250	270	mm

Main Specifications

Item	Specifications	Unit
Rated load	3000	kg
Rated bucket capacity	1.8	m³
Operation mass	10000	kg
Dumping height (from ground to main blade plate)	2930	mm
Dumping distance (from the front wheel to main blade plate)	1010	mm
Maximum breakout force	120	kN
Maximum traction force	90	kN
Lifting time of swing arm	5.1	s
Total cycling time	11	s
Minimum turning radius (outer edge of bucket)	6060	mm
Minimum turning radius (tire center)	5160	mm
Articulated angle	35	°
Gradeability	28	°
Tire size	17.5-25-12PR	
Overall demension of machine(L x W x H)	7050×2482×3025	mm
Engine model	YC6B125-T21	
Rated power/rotate speed	92/2300	kW/r/min
Travel speed	Gear I(F/R)	0 ~ 10/14
	Gear II(F)	0 ~ 16/25
	Gear III(F)	0 ~ 21
	Gear IV(F)	0 ~ 35

With the advancement of technology, product structure, specifications are subject to change without notice. In the event of discrepancy between the information and the actual product, the specification of the actual product shall be used as reference.